



# BES2610WD

Brief Datasheet

---

## Ultra-low Power Dual-mode Wi-Fi 6 and Bluetooth 5.4 Chip for Wireless Connectivity

---

### CONTACT US:

**Company:** Bestechnic (Shanghai) Co., Ltd. ("BES")

**Address:** 2F, Building B, Lane 2889 Jinke Road, Pudong, Shanghai (201203)

**Phone:** (86)21 6877 1788

For product inquiries and more information, please visit [www.bestechnic.com](http://www.bestechnic.com).

### DISCLAIMER:

*No part of this document may be reproduced or transmitted in any form or by any means, electronic or mechanical, including photocopying and recording, for any purpose, without the express written permission of BES. BES retains the right to make changes to this document at any time, without notice. BES makes no warranty of any kind, expressed or implied, with regard to any information contained in this document, including, but not limited to, the implied warranties of merchant ability or fitness for any particular purpose. Further, BES does not warrant the accuracy or completeness of the information, text, graphics, or other items contained within this document.*

## 1 General Description

The BES2610WD is an ultra-low power, highly integrated wireless connectivity chip designed for use in wearable applications. The platform incorporates a Wi-Fi 6 subsystem and a Bluetooth 5.4 subsystem, offering high-throughput wireless connectivity at high standards and cost-effective transmission over long distances. In addition, the platform incorporates a MCU subsystem comprising a STAR-MC1 processor, substantial SRAM, serial flash and a variety of interfaces.

The platform integrates an intelligent MAC design that includes a highly efficient offload engine and hardware data processing accelerators to completely offload Wi-Fi tasks from the host processor. The BES2610WD supports standards-based features for security, Quality of Service (QoS) and international regulations, delivering consistent reliable performance.

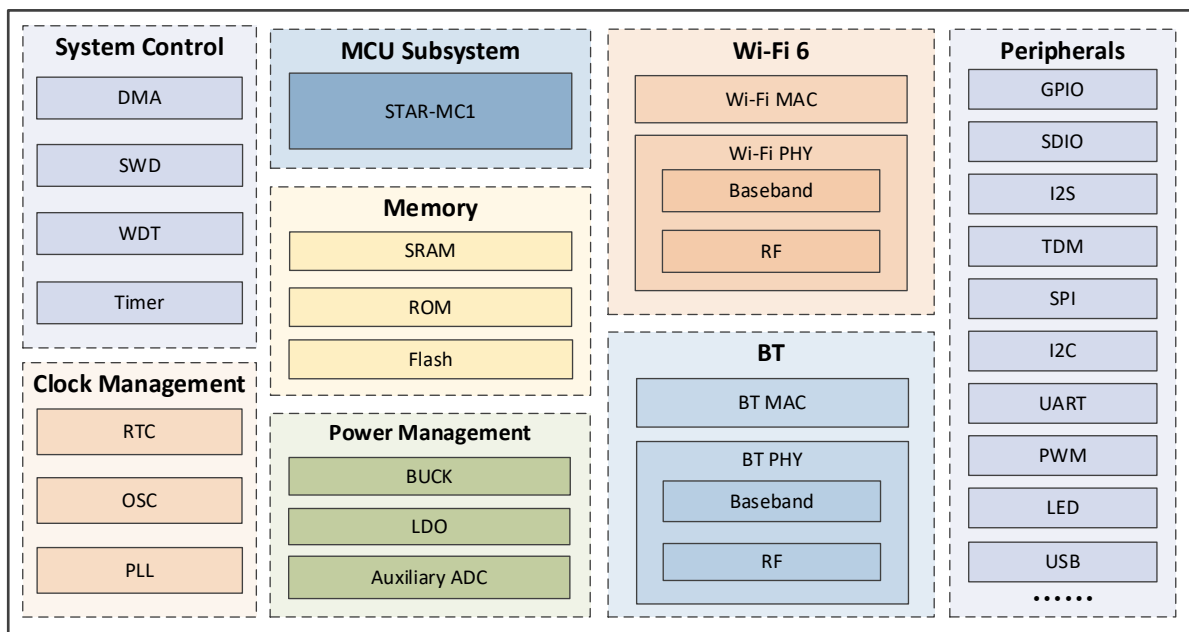

System Block Diagram

### 1.1 Applications

- Wireless connectivity for smart watches
- Other smart wearable devices

## 1.2 Features & Specifications\*

Wi-Fi/Bluetooth Subsystem	Dual-band Wi-Fi IEEE 802.11a/b/g/n/ac/ax
	Dual-mode BT 5.4
CPU Subsystem	STAR-MC1
Memory and Storage	Shared 1.25 MB SRAM
	boot ROM
	Flash in package
Peripheral Interfaces	GPIO/SDIO/I2S/TDM/SPI/I2C/UART/PWM/LED/USB.....
Package	111-pin FCCSP

\* The content in the table is subject to change without notice.